



Sensory Projector User Guide

This manual has been written to help you get the most from your Sensory Projector.

Please ensure that you read this fully as it contains important information. Failure to follow this advice may result in damage to the panel and invalidate your warranty.

Keep this manual in a safe place for future reference.

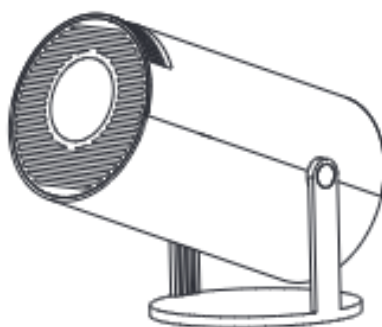

Unpacking

- 1.The projectors are shipped in specialist packaging, designed to protect the product from damage during transport.
- 2.Ensure that the packaging is carefully removed and keep the packaging in case the projector needs to be returned for any reason.
- 3.Take care not to lift by the lens end of the projector, as this can cause damage. Always lift from the base.
- 5.If you find any damage when you unpack you should report it within 7 days to your supplier.

Setting up and User Instructions

- 1.The projector is non dustproof or waterproof.
- 2.In order to reduce the risk of fire and electric shock, do not expose the projector to rain and fog.
- 3.Please use the original power adapter. The projector should work under specified rated power supply.
- 4.When projector is working, please do not look directly into the lens, the strong light will flash your eyes and cause slight pain. Children should use the projector under the supervision of adults.
- 5.Do not cover the vents of projector. Heating will reduce the life of projector and cause danger.
- 6.Regularly clean projector vents, or dust may cause cooling malfunction.
- 7.Do not use the projector in greasy, damp, dusty or smoky environment. Oil or chemicals will cause malfunction.
- 8.Please handle with care during daily use.
- 9.Please cut off the power if the projector is out of use for long time.
- 10.Non-professionals are forbidden to disassemble the projector for testing and maintenance

Product Descriptions and User Functions

This manual is for reference only. It is subject to change without prior notice.

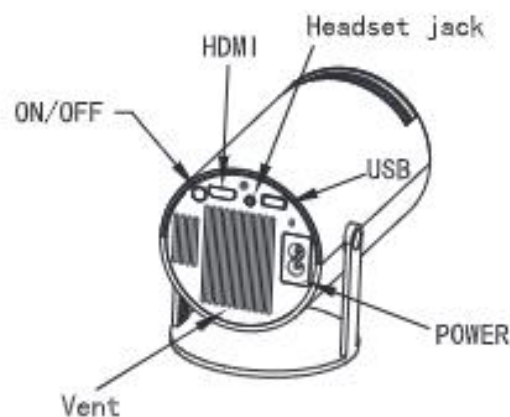

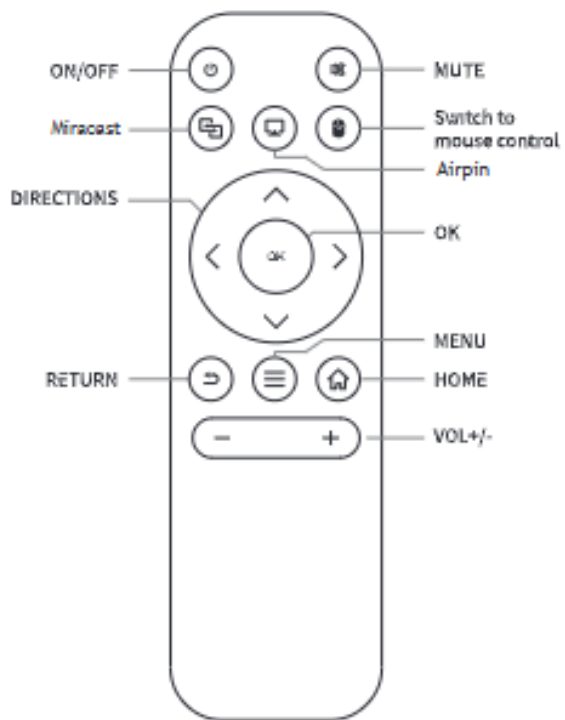
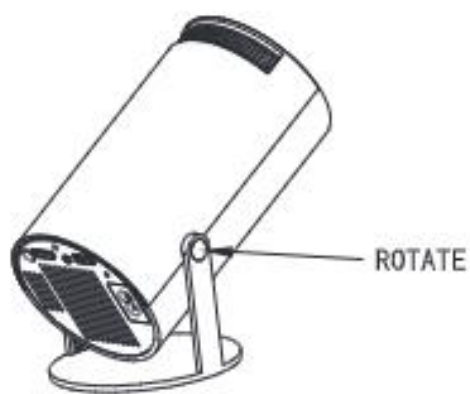
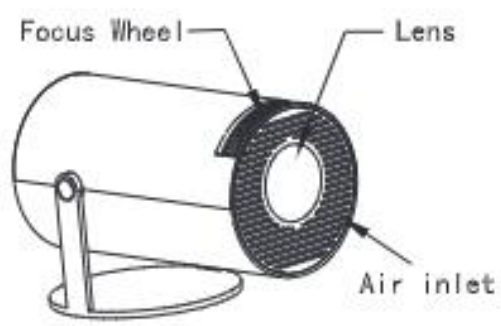

Switch in the Applications

Click on "My apps" to view installed programs, click program icon to switch between applications.

Move to "My Apps", click OK to enter.

All Apps' can be clearly distinguished from the icons

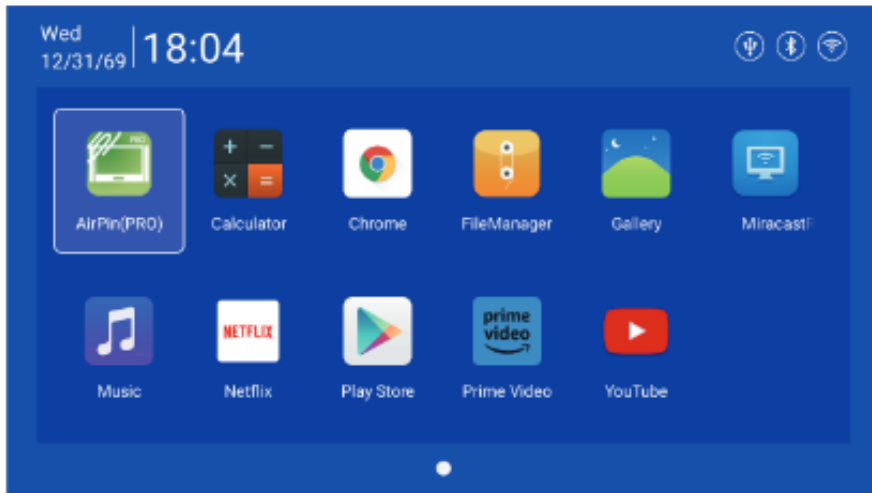

Settings

Enter to setup Networking, Bluetooth, Language, Other Setting, Projection, Audio Date & Time

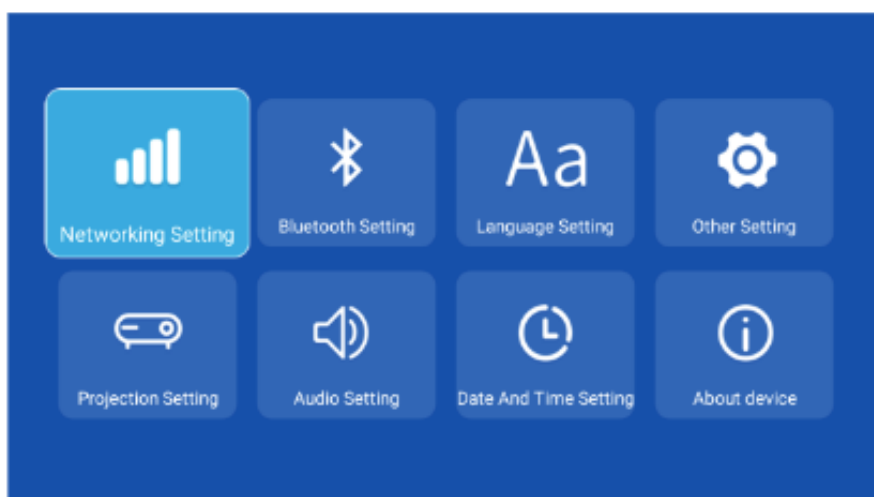

Networking Setting

Settings – Networking Setting – WIFI Setting, WIFI “ON”, select objective WIFI ID and input password to connect internet.

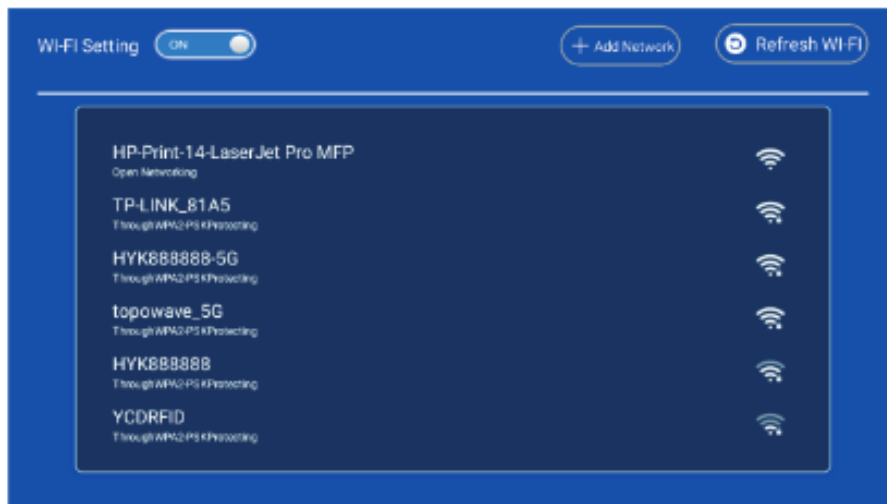

Bluetooth Setting

Settings – Bluetooth setting, Bluetooth “ON”, click Refresh Device, and choose device to pair.



Language Setting

Settings – Language Setting, enter to setup language and select input method.

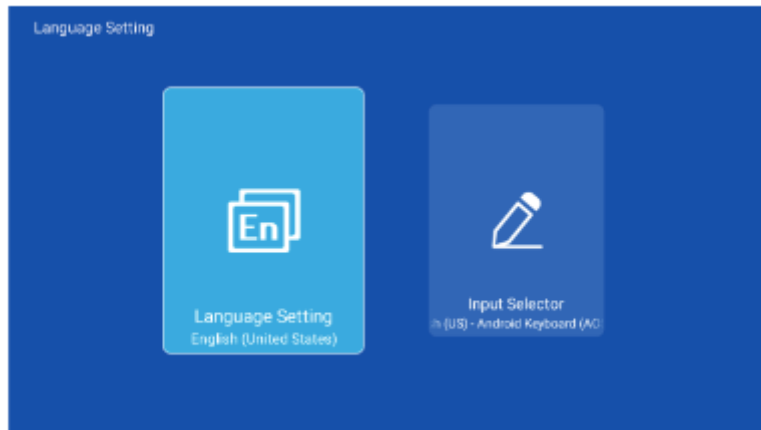

Other Setting

Setting - Other Setting, enter to get Application setting, Factory Reset Setting, and Developer Options.

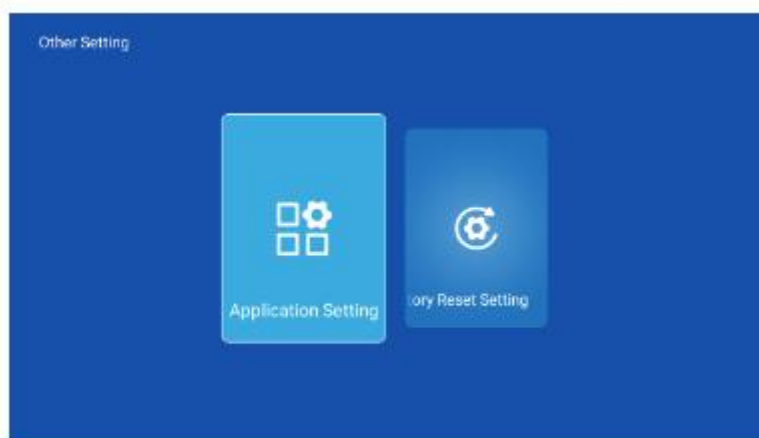

Projection Setting

Setting – Projector Setting, enter to setup projection mode, keystone correction.

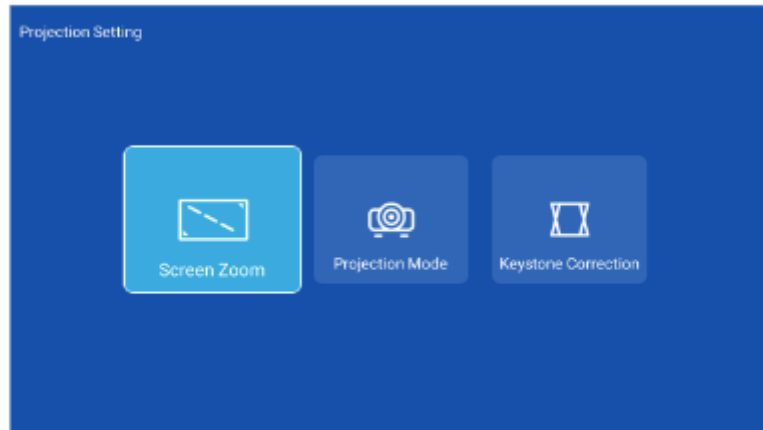

Audio Setting

Setting - Audio Setting, enter to adjust volume.

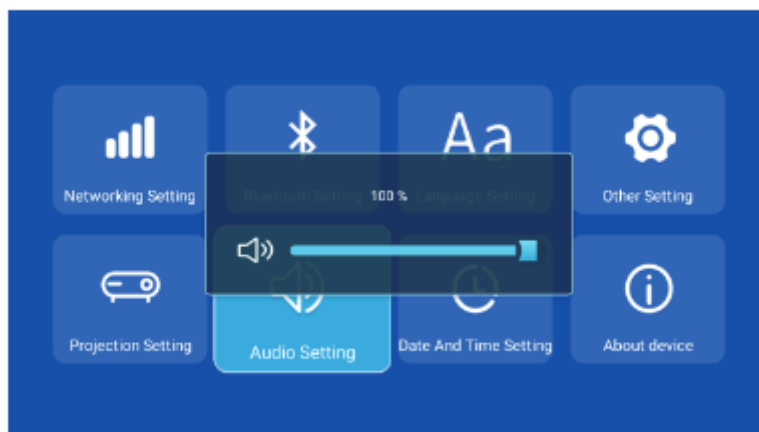

Date and Time Setting

Setting - Date and Time Setting, enter to setup time zone, time format, date format, date and time.

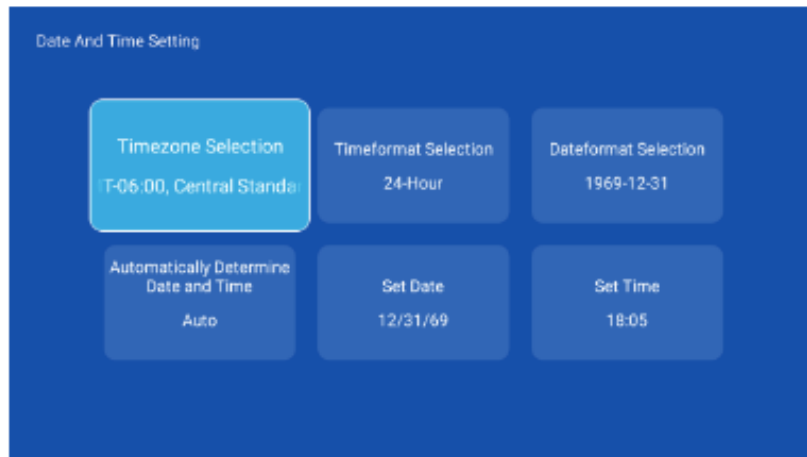

Signal

After connecting projector to other output device, enter HDMI or Audio/Video.



Miracast

Ensure that Android devices are in the same local wireless LAN with these devices

Operations on Devices:

Home Screen - My Apps - Miracast - Open Miracast Service - Turn on the phone mirroring - Connection.

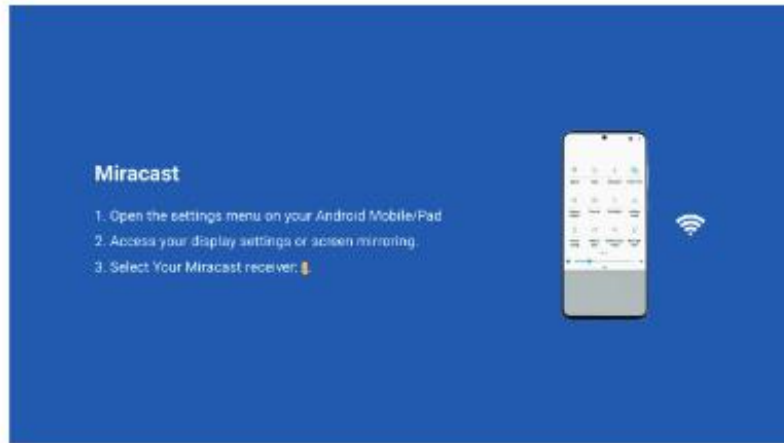

Operations Android phone devices.

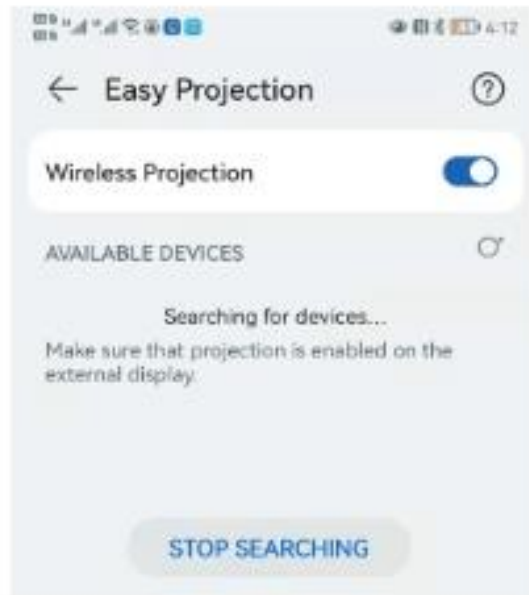

Airplay

Ensure that Apple devices are in the same local wireless LAN with these devices.

Operations on Devices

Home Screen – My Apps – Air Pin – Open Air pin service – turn on the phone mirroring – Connection.

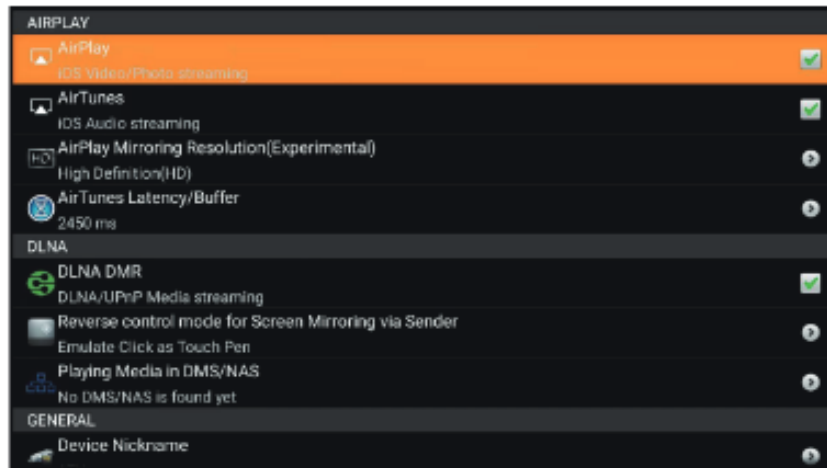

Potential Risks & Warnings

1. Read and understand all these instructions before using the Sensory Projector.
2. Please pay attention to important information related to the operation and maintenance of the projector. You should read this information carefully to avoid problems. Following safety instructions will increase the life of projector.
 - Please consult the qualified personnel for installation and repair services, and do not use damaged wires, accessories and other peripherals.
 - Projector should be kept away from flammable, explosive, strong electromagnetic interference (large radar stations, power stations, substations) ,etc. Strong ambient light (avoid direct sunlight), etc.
 - Do not cover projector vents.
 - Please use the original power adapter.
 - Keep adequate ventilation and make sure vents are not covered to avoid projector overheating
 - When projector is working, please do not look directly into the lens, the strong light will flash your eyes and cause slight pain.
 - Do not bend or drag the power cord.
 - Do not put power cord under projector or any heavy objects.
 - Do not cover other soft materials on power cord.

- Do not heat the power cord.
- Avoid touching power adaptor with wet hands

Sense Sensory Limited

www.sensesensory.co.uk 01702 810016 info@sensesensory.co.uk

